

The Ontogeny of Expression of Communicative Genes in Coyote–Beagle Hybrids

Alice Moon-Fanelli

Received: 10 February 2011 / Accepted: 16 February 2011 / Published online: 15 May 2011
© Springer Science+Business Media, LLC 2011

Abstract Although there are minimal genetic differences between the coyote (*Canis latrans*), the gray wolf (*Canis lupus*), and the domestic dog (*Canis familiaris*), these three species are extremely different in numerous aspects of their physiology, morphology, and behavior. In particular, the threat display of coyotes differs markedly from dogs and wolves. Coyotes display a wide open mouth gape-threat with attendant arched back defensive posture, and hiss vocalization. In our experience, this threat display is absent from the repertoire of the domestic dog and the gray wolf. We hypothesized that the foundation of these differences in species-typical threat displays is genetic. The threat displays of coyote–beagle crosses (F1's, F2's, F3's, F1F2's and beagle backcrosses), included the following phenotypes: that of each parental species, that of the domestic dog during pre-pubertal development switching spontaneously to the coyote gape-threat following sexual maturation; and a comparable phenotype requiring exposure to post-pubertal social stress-priming to bring the encoded genetic potential for the gape-threat to expression. The changeover from the dog snarl-threat to the coyote gape-threat was accompanied by a precipitous rise in endogenous cortisol levels over baseline. We hypothesized that where alternative genetic systems are physically available, their selective expression in development may depend on environmental events, such

as social stress, to affect internal mechanisms that ultimately control the phenotype. Exogenously elevated cortisol levels, in the absence of the subjective experience of social stress, were associated with the onset of the expression of the coyote threat pattern in an F1 hybrid possessing a full haploid complement of coyote genes and his backcross offspring resulting from a breeding to his F2 daughter. With oral doses of hydrocortisone, the cortisol levels were substantially elevated over basal levels. With endogenous cortisol priming, an increase up to five-fold over those levels obtained with social stress was associated with the expression of the coyote phenotype.

Keywords Coyote · Dog · Behavior genetics · Communication · Stress

Introduction

The purpose of this investigation was to study the transmission of genetic components of canid threat behavior by comparing two related species (*Canis latrans*, *Canis familiaris*) that differ in observable behavioral components, and their F1 (coyote (male) × beagle (female), F2 (F1 × F1), F3 (F2 × F2), F1F2 (F1 × F2), and backcross (F1 × beagle) hybrids.

Coyotes (*Canis latrans*) and domestic dogs (*Canis familiaris*) differ in their species typical defensive threat displays. The threat patterns for the coyote have previously been described by Fox (1970, 1971, 1975) and Lehner (1978). Coyotes exhibit a distinctive wide open mouth gape-threat, arched back posture, mincing gait, and hiss vocalization. In my experience, these behaviors are not shown by the domestic dog.

Using pedigree analyses, the three major elements of the coyote defensive threat behavior segregated independently

Edited by Stephen Maxson.

The paper originated in a festschrift, Nurturing the Genome, to honor Benson E. Ginsburg on June 2, 2002 and is part of a special issue of Behavior Genetics based on that festschrift.

A. Moon-Fanelli (✉)
Animal Behavior Consultations, LLC, Brooklyn Veterinary
Hospital, 150 Hartford Rd., Rt. 6, Brooklyn, CT 06234, USA
e-mail: amoonf02@charter.net

in the F2, F1F2, and F3 generations. This leads to the inference that the genes underlying each behavior are carried on separate chromosomes and raises the question of how these three behaviors come to be expressed in an integrated manner. Furthermore, they represent an attempt to identify segregants from the pedigree analyses (putative genes) that serve a communicative function in a higher mammal.

Materials and methods

Description of the phenotypic endpoints

The domestic dog and the gray wolf typically exhibit the snarl-threat in defensive encounters and have not been reported to exhibit the distinctive coyote gape threat. The snarl is characterized by a closed or partially open mouth with the lips retracted to expose the canines and the incisors (Fig. 1). The accompanying vocalization is typically a low, rumbling growl. Spectrographic analysis of growl vocalizations indicate that they consist of several bands of low frequency sound energy (Schotté and Ginsburg 1978). In defensive encounters, the domestic dog never exhibits an exaggerated arch to the back which is characteristic of the coyote. Depending on the animal's level of arousal, the body may be held erect, accompanied by piloerection, with the head elevated but retracted and the tail tucked (Fig. 2).

While the coyote can and does express the snarl-threat, usually as a lower intensity threat, the species-typical defensive threat gesture of the coyote is a gape. The gape-threat is characterized by an extremely wide and sustained open mouth, with the lips retracted (Fig. 3). The species-typical vocalization is an aspirated, sibilant hiss. The hiss is emitted from the throat. Spectrographic analysis of the hiss vocalization has revealed that it consists of a wide range of frequencies of approximately equal levels of sound energy,



Fig. 1 Snarl-threat: F2 coyote–beagle hybrid



Fig. 2 Domestic dog defensive posture: F2 coyote–beagle hybrid



Fig. 3 Gape-threat: coyote

a pattern resembling that of white noise (Schotté and Ginsburg 1978). The accompanying body posture consists of a lowered head and tail and an exaggerated arched back, giving the animal an inverted U-shaped appearance (Fig. 4). The stance is elevated on the toes and there is often a mincing gait (Fig. 5). Coyote gapes in the type of defensive situations was observed where the dog expresses the snarl threat. In terms of its communicative function, the gape-threat is equivalent to the defensive snarl exhibited by the domestic dog.

In my research, the coyote gape-threat, its accompanying hiss vocalization and arched back body posture were completely absent from the behavioral repertoire of the domestic dog. The coyote is capable of exhibiting the threat pattern of either species, depending on the social context. Consequently, in observing the hybrids, the critical comparison was between the presence of the unique components of the coyote repertoire and that of the domestic dog. Furthermore, all three components constitute the

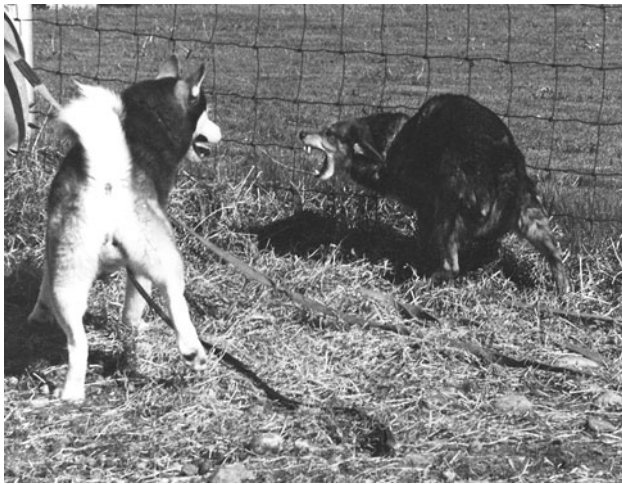

Fig. 4 Coyote defensive posture and gape: F1F2 coyote–beagle hybrid



Fig. 5 Coyote defensive posture: F1F2 coyote–beagle hybrid

coyote species-typical threat pattern, but depending on the animal's level of arousal, they do not necessarily occur together all of the time. This is true for coyotes as well as the hybrids. For this study, I considered each of the components of the coyote defensive display separately. To be classified as a gaper, an animal only needed to demonstrate the wide open mouth characteristic of the gape-threat with an appropriate vocalization. Such vocalizations included the hiss and the growl, or no vocalization, all of which are typical of the coyote. It is important to take note of the vocalization. During defensive encounters, many of our hybrids emitted “scream” vocalizations which were accompanied by a wide open mouth. These threats were not classified as gapes since the animal was opening its mouth wide to vocalize. The gape-threat was also distinguished from open mouth bite intentions which occurred during play or aggressive encounters. The gape-threat was not accompanied by a rapid forward head movement and

the mouth was held wide open. The gape-threat appears to be a stereotyped behavior pattern and any variability in its expression was considered to be associated with the intensity of the threat.

Finally, some of the hybrids in this study exhibited partial patterns of the coyote behavior prior to expressing the full gesture. These premonitory behaviors included the hiss-growl which contained a sibilant component to the vocalization which was verified by sonogram-analysis, aspects of the coyote defensive body posture, including a slight arch to the back, and the “pre-gape.” The pre-gape was characterized by a partial opening of the mouth, frequently with no vocalization. The partial open mouth threat was sustained and not followed by any forward head motion which might indicate a bite intention. It is a response not observed in domestic dogs, and it was easily distinguished from other gestures that involve opening the mouth. In the coyote, a partial opening of the mouth is considered a lower intensity threat. When the coyote is emitting a partial open mouth signal, it shifts to a wide open mouth threat when the intensity of the aggression increases or the other participant moves closer. In the prepubertal hybrids, the repeated expression of partial patterns, such as the “pre-gape” or the “hissy-growl” were used as potential indicators as to which animals might have had the genetic potential to express the gape-threat. Depending on the hybrid's genetic background, the complete behavior may not be expressed until after the animal is sexually mature, suggesting hormonal involvement. The onset of premonitory behaviors was observed in post-pubertal hybrids as well. The onset was frequently associated with their initial exposure to social stress. All but one out of 23 hybrids of various generations that emitted the pre-gape eventually responded with the wide open mouth gape threat characteristic of the coyote. In terms of the expression of the gape in our hybrids, no blending inheritance was observed. All hybrids that were classified as gapers emitted the full wide open mouth gape characteristic of the coyote.

Subjects

The study population was derived from an initial cross between a female beagle and a male coyote (Fig. 6). The beagle was derived from five generations of brother–sister matings from the laboratories of Scott (Scott and Fuller 1965). The behavior and physiology of these beagles had been extensively studied, providing benchmarks for any behavior to be investigated (Scott and Fuller 1965). Because these dogs had been carefully observed over generations of inbreeding, we were quite certain that the gape was not being carried along as a recessive in the Jackson Laboratory beagles.



Fig. 6 Breeding pair: male coyote (gape) and female beagle

The male coyote used as the foundation sire was the product of a father–daughter mating. His dam was the product of a brother–sister mating that was derived from a brother–sister mating. This represented minimally three generations of close inbreeding. There was no reliable information as to whether the original generation was itself inbred. From Wright's (1921) graph which estimates the percentage of inbreeding under various inbreeding systems, we calculated the coyote sire's coefficient of inbreeding to be approximately 50%.

General paradigm for conditions of rearing

Except in the case of large litters which were split, all pups remained housed with their littermates in the juvenile facilities until they were moved to the adult kennel facility.

Both the juveniles and the adults were exposed to domestic dogs, wolves, coyotes and other coyote–beagle hybrids. All of the F1 hybrids were raised by a beagle dam and thus were not exposed to the gape-threat prior to weaning. The F2 gapers were also reared by non-gaping F1 dams. Some of the F3 offspring were reared by dams that exhibited the gape threat. The threat phenotype of the dam had no obvious or measurable effect on the phenotypic threats of the offspring. Additionally, all adult animals had at one time or another been housed with gapers, including coyotes, and non-gapers, including wolves, with no apparent effect on their subsequent phenotypic threat behavior. Based on these observations, we concluded that the hybrids were not imitating the animals with which they were housed, nor were they being reinforced for exhibiting a particular threat gesture. To further emphasize the genetic basis of the coyote threat configuration, the gape-threat was elicited in some early-gaper hybrids as early as 2 weeks of age, before the eyes and ears function, and thus at a developmental stage that precluded learning. All canids, including wolves, domestic dogs, coyotes and non-gaping hybrids, responded appropriately to the gape-hiss threat

gestures directed towards them, which indicated that members of the genus that do not emit this threat pattern are nevertheless capable of decoding it, probably based on additional information from affective communication.

Observations

Periodic observations focusing on dominance relations and threat behaviors were made throughout the day on a random schedule. All records were maintained in notebooks designated by litter. The recording techniques were not restricted to checklists because much valuable information would be lost if we had reduced the complex affective communicative behavior of these animals entirely to simple, discrete categories. However, checklists were found to be useful for recording and summarizing the occurrence of the primary threat gestures. The relevant threat behaviors were coded and a standardized scoring form was devised to expedite the recording of this information during testing. These checklists were used in conjunction with the descriptive data. Photographic and video records were maintained for each type of behavior to aid in the actual analysis and scoring of the behaviors and to obtain a permanent record of the developmental stages of threat behavior. When possible, key behavioral tests were video recorded and the results were summarized in the notebooks and in the threat scoring sheets.

Behaviors recorded

During behavioral testing and daily observations, all incidences of threat behavior were recorded. For both juveniles and adults, this included noting the occurrence of gape-threats and snarl-threats, as well as any accompanying vocalizations and body postures. Additionally, premonitory behaviors were recorded to facilitate identification of those animals that might have the genetic potential to express the coyote defensive threat configuration.

The following information was noted for each animal: the threat eliciting stimulus, the context of the interaction, the dominance–subordination relationships and “emotional status” of the interactors, the initiator of the encounter, as well as some aspects of affect. Dominance was assigned on the basis of the relative frequency and the outcome of several classes of interactions, as well as observations of affect, the tendency to defer, and the frequency of participation in activities. Particular attention was paid to the type of threat gesture emitted, and any transition from one gesture to another, as well as other behaviors associated with aggression, such as biting, fleeing, body slams, body blocks, pinning, and dominance scratching. At the same time, the proximity of the other animals, their activity and affective communicative behavior were noted as well. The

frequency and the ease (latency and stimulus intensity) with which the gape was elicited under each testing situation were also noted in an attempt to subjectively identify threshold levels.

Genetic experiments

Throughout the duration of this project, seventeen crosses were produced from an initial cross between a highly inbred female beagle and a partially inbred male coyote (Fig. 6). A total of 61 hybrids were observed in the study (Table 1). The generations bred included one F1 litter consisting of six individuals. The sole F1 male was bred to two of his littermates to produce four F2 litters for a total of 21 F2 offspring. Eight of these F2 hybrids were bred in various combinations to produce seven F3 litters totaling 16 animals. Thirteen F1F2 offspring were produced from four F1 × F2 matings. Finally, five beagle backcross pups were produced by crossing a male beagle with a female F1. The male beagle was a littermate of the female beagle dam for the F1 litter.

The methodology of these crosses revealed information about the heredity of the coyote defensive threat posture, including the possibility of segregating elements. When the coyote genes are put on the unbuffered dog background, whatever genetically integrates the coyote threat pattern in the coyote was disrupted in the hybrids to reveal

information about hereditary factors as well as the segregation of the individual components (Ginsburg 1976a).

Results

Segregation of the coyote threat repertoire

After reviewing the pedigrees for the coyote–beagle hybrids, it was evident that the three components of the coyote threat repertoire segregate independently, suggesting there are independent genetic systems coding for the expression of the gape-threat, hiss vocalization and the coyote defensive posture. For those hybrids that did not display one or more of these behaviors, additional or different testing may have brought other components to expression if the expression of the coyote threat phenotype in the hybrids was dependent upon the level of stimulation. However, under the conditions of our experiments, the data indicated that the gape-threat, hiss vocalization and defensive posture can and did exist in any combination with each other (Fig. 7).

Based on these data, we inferred that the capacity for the component behaviors must be encoded by independent genetic systems located on separate chromosomes. We postulated that the coyote is homozygous for the genes for the gape-threat, hiss vocalization, and the coyote defensive posture. However, the hybrids may be heterozygous and may not have inherited all three genetic systems.

Table 1 Early-gaper phenotype: age onset of gape

Weeks of age	Generation			N/Age
	F2	F3	F1F2	
0–1.5	0	0	0	0
2.0	0	4	0	4
2.5	1	1	0	2
3.0	1	3	2	6
3.5	1	1	0	2
3.75	0	1	0	1
4.0	2	2	1	5
4.5	1	0	0	1
5.0	2	0	2	4
5.5	0	0	0	0
6.0	0	0	0	0
6.5	1	0	0	1
7.0	1	1	1	3
7.5	0	0	0	0
8.0	0	1	0	1
8.5	0	0	0	0
9.0	0	1	0	1
N/Generation	10	15	6	31

Introduction to the genetics of the gape-threat

Threat behavior of our coyote–beagle hybrids could be classified into four distinct phenotypes: *early-gapers*, *non-gapers*, *spontaneous late-gapers*, and *stress-primed late-gapers*. Each of these phenotypes will be considered separately for the gape-threat. In addition, two of the three hybrids which received exogenous doses of cortisol completely switched to the coyote threat pattern without exposure to the affect of social stress. The inheritance and segregation of the complete coyote threat configuration, consisting of the defensive posture and the hiss-vocalization as well as the gape-threat, is discussed below.

The early-gaper behavioral phenotype

Age of onset Out of a total of 61 coyote–beagle hybrids, 31 animals were identified as early-gapers from the F2, F3, and F1F2 generations. None of the F1 or beagle-backcross hybrids were observed to emit the gape-threat prior to reaching puberty. Additionally, no animals exhibited threat behavior of any kind prior to 2 weeks of age. Six F2 and F3 hybrids first emitted the gape-threat between two to

Fig. 7 Segregation of components of coyote threat repertoire in coyote–beagle hybrids

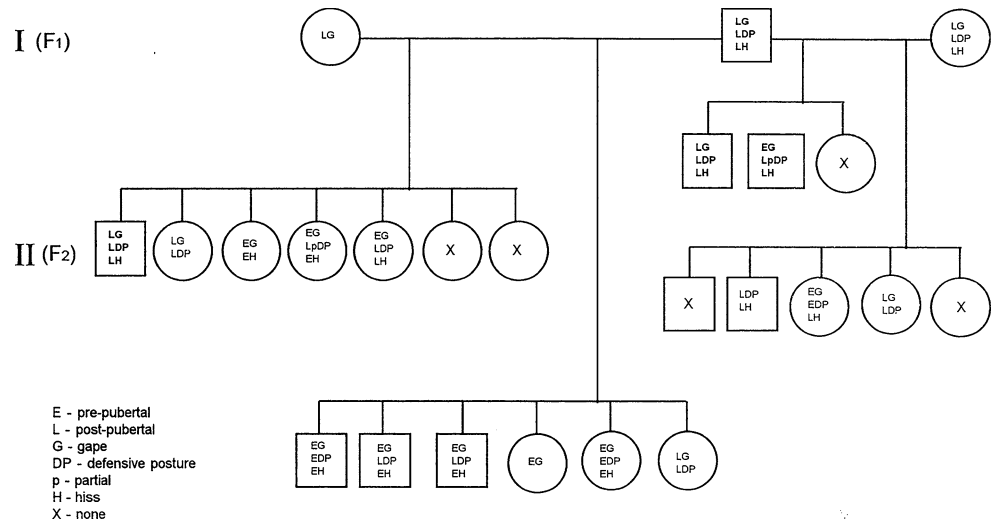

two-and-one-half weeks of life, before the sense of vision and hearing are completely functional (Table 1). Nineteen animals gaped between 3–5 weeks of age. Thus 25 out of 31 animals, constituting 81% of the early-gapers, first emitted the gape-threat prior to 5 weeks of age. The remaining six early-gaper hybrids exhibited the onset of the gape-threat between six-and-one-half to nine weeks of age. Whereas the F2 and F1F2 hybrids showed a wider range of age of onset for the gape, 12 out of 16 of the F3 hybrids, constituting 75%, gaped between 2–4 weeks of age. Only one of the 16 F3 hybrids was classified as a non-gaper but he was not tested beyond five months of age. The narrower range and earlier age of onset of the gape-threat in these F3 early-gaper hybrids may be attributed to the higher penetrance of the F2 parents. All of the early-gaper F2 hybrids crossed to produce the F3 generations gaped prior to four-and-one-half weeks of age.

Gape onset eliciting stimulus For all the early-gapers, the onset of the gape-threat occurred in response to relatively benign testing conditions ranging from routine daily handling and dam-sib interactions to specific tests designed to elicit the gape-threat. Due to variations in the temperaments of the animals, the tests were designed to encompass a wide range of stimuli including brief isolation, interactions with human handlers, and interactions with familiar as well as unfamiliar canids. Some animals never exhibited fear of nor the tendency to threaten humans, whereas they became highly defensive in the presence of an unfamiliar adult canid. The reverse situation also occurred in which the animal was highly defensive towards humans, but completely submissive when interacting with other canids. Because of the young age of the early-gapers and the ability to control their experiences prior to testing, it was possible to take advantage of the element of novelty while sequencing the tests, such that an increased variety of stimuli could be presented as the pups matured. In order of

their administration and relative severity, these tests included the Head-Stroke Test (1–4 weeks of age), the Crate Test (3–6 weeks of age), the “walk towards” of the Puppy Handling Test (3–16 weeks of age), and the Unfamiliar Adult-Canids Test, (from 7 weeks through adulthood).

Spontaneous late gapers

Social stress-primed late-gaper behavioral phenotype The stress-primed late-gaper category included those animals that, after reaching sexual maturity, progressively switched from the snarl to the gape-threat only after exposure to a prolonged period of social stress-priming. Social stress was induced by housing the subject animal in a run with one or more dominant canids. A total of eight hybrids from the F2 and F1F2 generations responded to post-pubertal social stress-priming by altering their phenotypic patterns from the snarl to the coyote gape-threat. Subjects of this genotype were identified partly by exclusion since they had not shown the gape-threat even though they were post-pubertal and had been exposed to eliciting stimuli. This alone may have been insufficient, however, as it may be that they simply did not carry the appropriate genes to enable them to emit this behavior. They could, however, be identified by means of premonitory behaviors which were expressed prior to the progressive transition from the snarl to the coyote pattern. For six of the eight stress-primed late-gapers, the onset of premonitory behaviors coincided with their initial exposure to post-pubertal social stress. The remaining two animals expressed premonitory behaviors during pre-pubertal testing. The onset of the expression of one or more premonitory behaviors occurred simultaneously in some instances and sequentially in others.

Soon after their initial exposure to social stress-priming, the non-gapers began to express low intensity premonitory

behaviors. As the period of time they were exposed to this stress lengthened, the intensity, frequency, and number of premonitory signs emitted increased. For example, the hybrid may have expressed the defensive posture during its initial exposure to social stress, but only exhibited the snarl-threat. This may be followed in subsequent tests by pre-gapes but the animal would continue to predominantly emit snarls. Towards the end of stress-priming, the animal rarely exhibited the snarl and preferentially expressed the pre-gape until it eventually switched to the gape-threat. Throughout this transition period the defensive posture continued to be expressed. The premonitory patterns varied for each hybrid.

We had no evidence, in the context of these experiments that the stress-primed late gapers were learning to gape via behavioral reinforcement. Additional evidence gathered from our experiments also indicated that the frequency and intensity of harassment by the dominant stressor animal/s did not appear to increase, diminish or change in any fashion in response to the type of defensive threat gesture the stress-primed late-gaper employed. Finally, once the gape threat was emitted, all stress-primed late-gapers continued to express this threat gesture during subsequent defensive encounters.

Because this was a longitudinal investigation encompassing 18 years of study, the amount of testing and the testing procedures were not equal for each animal. The knowledge gained from years of observation allowed us to more successfully test higher threshold animals. The social stress-priming process and the Unfamiliar Adult Canid/s in a Novel Environment test were particularly useful for this purpose.

Hormonal correlates of the social stress-primed late-gaper behavioral phenotype Cortisol is the primary glucocorticoid secreted by the canine adrenal cortex and its elevation is associated with stress. Therefore, we examined the cortisol levels during the various stages of social stress-priming and the behavioral transition for five of the eight stress-primed late-gapers whose behavioral transitions were previously described. Data for a stress-primed F2 male who remained a non-gaper following his exposure to two prolonged social stress-priming situations are also included in this section. A description of the developmental histories of these socially stress-primed late-gapers with reference to the cortisol levels associated with the various stages of behavioral expression illustrates the relationship.

Resting cortisol levels in awake, trained and restrained domestic dogs (*Canis familiaris*) are usually 1.00 $\mu\text{g}/100\text{ ml}$ or less (Lilly et al. 1986). Following the stress of a moderate hemorrhage, the levels are elevated to 8.0 $\mu\text{g}/100\text{ ml}$.

Following a more severe hemorrhage, the cortisol levels may reach 10–12 $\mu\text{g}/100\text{ ml}$ (Lilly et al. 1986). Resting cortisol levels for the coyote (*Canis latrans*) are unavailable from the literature. As described below, all serum samples for our coyotes, beagles and hybrids were evaluated for cortisol by radioimmunoassay (RIA) techniques by W. C. Engeland. Based on two samples collected in the morning from one of our male coyotes, these levels are comparable to those of the domestic dog, measuring 1.34 $\mu\text{g}/100\text{ ml}$ and 1.44 $\mu\text{g}/100\text{ ml}$ with a mean of 1.39 $\mu\text{g}/100\text{ ml}$. This animal was relatively unsocialized to human handling and untrained for blood collection, thus requiring restraint, which probably accounted for a slightly elevated measurement when compared with the dog. Two morning samples were collected from one of our male beagles. These measured 0.75 $\mu\text{g}/100\text{ ml}$ and 0.85 $\mu\text{g}/100\text{ ml}$, with a mean of 0.80 $\mu\text{g}/100\text{ ml}$. This animal, though inexperienced with blood sampling procedures, was accustomed to human handling and did not require restraint. The resting cortisol levels for seven of our coyote–beagle hybrids ranged from 0.40 $\mu\text{g}/100\text{ ml}$ to 2.15 $\mu\text{g}/100\text{ ml}$ with a mean of 1.15 $\mu\text{g}/100\text{ ml}$. These baseline levels, in comparison to those obtained by W. C. Engeland for his domestic dogs, measuring 1.00 $\mu\text{g}/100\text{ ml}$ or less, are slightly elevated. While we cannot be certain whether these values reflect a physiological difference between the species or a reaction to the collection procedures and the greater stress these procedures produced in the unsocialized coyote and the hybrids, it seems reasonable to attribute the difference to the latter.

To avoid subjectively correlating the observed levels of behavioral stress with correspondingly high or low cortisol levels, the serum sample categories represented by the bars on the histograms were separated, where possible, according to the different animals with which the stress-primed hybrid was housed. Hypothetically, this would reflect exposures to different levels of social stress. When this was not possible, because the same animals were continually housed together, clear changes in position in the dominance hierarchy provided the necessary marker for grouping the samples. We predicted that alterations in the housing or dominance relationships would affect the level of stress to which the animal was being exposed. In this way, we hoped to avoid biasing our results by subjectively grouping the samples representing high levels of cortisol with what we considered, based on our behavioral observations, to be high levels of social stress. In four out of five instances, such unbiased separation of the samples revealed a definite increase in cortisol correlated with the onset of the gape-threat. In the other case, no clear correlation could be made with the onset of the gape-threat and a corresponding surge in cortisol levels.

Cortisol-primed late-gaper phenotype

To more directly test the hypothesis that priming by social stress of a post-pubertal hybrid can reprogram the phenotype by hormonal de-repression of the coyote genetic system, in the final phase of these experiments we administered cortisol directly in subjects who lacked the affective experience of social stress-priming. This allowed us to examine if elevated hormone levels alone were sufficient to bring the coyote genome to expression, or whether, in addition, the subjective experience of social stress was necessary. Such social stress effect could possibly act through an increase in the number of receptor sites or their ability to bind cortisol.

To investigate this question, we attempted to mimic the eliciting cortisol profile induced by social stress through administering daily oral doses of hydrocortisone to the three male non-gaping hybrids (F1, F2, F1F2). These animals were not experiencing social stress and had not expressed the gape-threat during previous tests. The F1 and his F1F2 offspring had never been exposed to stress-priming, but had exhibited premonitory behavior during standard tests. The F2 had undergone repeated stress-priming and had exhibited extensive premonitory behavior, but had never clearly expressed the wide open mouth coyote gape-threat. As with the social stress-primed late-gapers, we have included the standard errors measured for the animals in the cortisol-priming experiment. However, again, these values represent small numbers and may also be inflated because they include biological variation as well as what would conventionally be included in an error term.

Summary: cortisol-primed onset of the gape-threat Our social stress-priming data suggested a relationship between an increase in endogenous cortisol levels over a prolonged period and a change in the expression of species-typical threat gestures in our coyote–beagle hybrids. Therefore, we attempted to induce a behavioral change, specifically a switch from the snarl to the gape-threat, by raising the concentration of cortisol exogenously without allowing the animal to experience the affect of prolonged social stress. With the oral doses of hydrocortisone, the cortisol levels for all three animals tested were substantially elevated over basal levels, and increased up to five-fold over those levels obtained with social stress alone. These elevated cortisol levels, in the absence of the subjective experience of social stress, were positively correlated with the phenotypic expression of the coyote threat pattern in the F1 hybrid, where the complete coyote genome is encoded. Elevated cortisol levels were also associated with a high threshold for expression of the gape-threat in his F1F2 offspring. Both the F1 and the F1F2 continued to emit the coyote defensive gape threat after their cortisol levels returned to

baseline. This indicated to us that elevated cortisol levels did not need to be maintained for the behavior to be expressed.

Although exogenous cortisol-priming was not sufficient to re-program the phenotype of the F2 mentioned, the activation of the coyote genetic system in five other hybrids from segregating generations was associated with a rise in cortisol induced by social stress. It is possible that exogenous doses of cortisol might be necessary, but not sufficient, to re-program the phenotype of hybrids other than those which possessed the full complement of requisite coyote genes.

Furthermore, much higher cortisol levels were required to activate the coyote genetic system exogenously with oral doses of cortisol, than with endogenously elevated cortisol levels resulting from social stress-priming. The lowest mean obtained with any of these cortisol-primed hybrids was two to five times that obtained as the maximum priming response for the socially stressed animals that changed their behaviors. It appeared, therefore, that exogenously administered cortisol was not as efficient as social stress induced endogenous increases.

Finally, the variations in cortisol levels obtained while these three animals, conditioned to blood drawing, received the same daily dose of exogenous cortisol, argues for an additive effect of exogenous cortisol. If the adrenal was suppressed while they were receiving oral doses of hydrocortisone, one would expect less variation in serum cortisol levels. Since we measured large variation in cortisol levels this would indicate that their adrenals were not totally suppressed.

Summary: gape-threat phenotype

We identified five phenotypes with regard to the expression of the coyote gape-threat in our coyote–beagle hybrids, involving differences in developmental, experiential, genetic and hormonal factors. From a total of 61 hybrids, 31 early-gapers emitted the gape pre-pubertally, five animals spontaneously switched their behavior from the snarl to the gape during or after puberty, eight did so only after social stress-priming, two of the three hybrids primed with exogenous doses of cortisol switched to the coyote threat without concomitant exposure to social stress, and 15 never expressed the coyote gape-threat.

The early-gaper phenotype was expressed well before the animal reached puberty and was often elicited under benign testing conditions. The spontaneous late-gapers exhibited the typical threat pattern of the dog until they were post-pubertal, after which they spontaneously switched to the coyote open mouth gape-threat. The post-pubertal stress-primed late-gapers progressively switched from the snarl-threat to the gape only following exposure to

a prolonged period of social stress-priming. An increase in premonitory behaviors was usually observed in response to the social stress and the behavior changes were often associated with an increase in cortisol levels. We measured a three-fold increase in cortisol levels over baseline prior to the onset of the gape-threat for four of the five stress primed animals tested. All of the hybrids, from every category, continued to express the gape-threat once it was emitted. Fourteen of the fifteen non-gapers were terminated from the research prior to the development of the Unfamiliar Adult Canids in a Novel Environment tests designed to elicit the gape from high threshold hybrids. The F2 non-gaper that was thoroughly tested did not switch to the gape despite repeated exposures to social stress-priming and cortisol-priming.

Hormonal and behavioral correlates of social stress

Historically, the concept of stress has been associated with changes in the endocrine system, particularly the pituitary–adrenal (P–A) system. Selye (1950) was the first to directly address the relationship between stress and glucocorticoids in his formulation of the General Adaptation Syndrome (GAS). His synthesis of the physiological responses to stress led to numerous studies which investigated the role of stress in the activation and inhibition of the P–A system.

In our study comparing the cortisol concentrations between three male coyote–beagle hybrids actively engaged in a social stress-priming experiment, the omega animal’s cortisol levels were consistently higher during periods of active high level social stress than levels measured for the alpha and beta stressor animals (Fig. 8). However, during periods of mild to moderate social stress, the omega animal’s cortisol levels were intermediate or overlapped the levels of both stressor animals. The alpha animal’s cortisol levels were consistently lower than those measured for either of the other two hybrids. This animal was consistently dominant in all social stress-priming situations in which he served as a stressor animal. In contrast, the beta stressor in this experiment had also been stress-primed and had not developed a consistent “style of dominance.” His cortisol levels were more variable and were slightly elevated in comparison to those measured for the alpha stressor. Thus, decreased cortisol levels were measured for the dominant male which had a style of dominance that afforded him control and predictability, whereas those animals that were accustomed to social instability in dominance hierarchies, even if they were dominant in certain situations, exhibited variable or elevated cortisol levels. These results are in agreement with Sapolsky and Ray’s (1989) measurements of cortisol variation in relation to dominance in wild olive baboons.

Social stress and gene expression in hybrids

The identification that a social stress priming mechanism is antecedent to the full expression of the gape-threat in coyote–beagle hybrids has ecological and evolutionary implications as an example of the selective activation of genetic systems during development. Social stress plays a part in the development and maintenance of any dominance hierarchy. When an animal is part of a dominance hierarchy and is not the dominant animal, it may be socially stressed just by the presence of the other animals in that social group. Thus, the design of these experiments mimics, to a certain extent, a natural ecological situation. The socially stress-primed post-pubertal hybrids experienced the normal social stresses associated with being intermediate or low in the dominance hierarchy, plus the additional social stress of being in a combative situation. This experience with social stress is associated with increased cortisol levels, hypothetically leading to the activation of the genes responsible for the expression of the behavioral motor components of this integrated genetic system. The attainment of sexual maturity in both sexes appears to be a prerequisite for the expression of the gape-threat in spontaneous late gaper hybrids of the appropriate genotype. In other genotypes it is a necessary but not a sufficient factor. These stress primed late gaper hybrids required the additional priming of a social stress mediated cortisol increase.

Comparing the cortisol levels between an F1F2 stress primed animal and the alpha and beta stressor animals we observed that the cortisol levels of the primed animal increased over time as the stressors increased the level of harassment (Fig. 8). For both stressor animals, even when they were providing high levels of stress, their cortisol levels remained within the normal resting level range measured for our hybrids. In this example, the alpha F2 stressor animal’s cortisol levels were always slightly higher and showed more fluctuation than the beta F2 stressor animal.

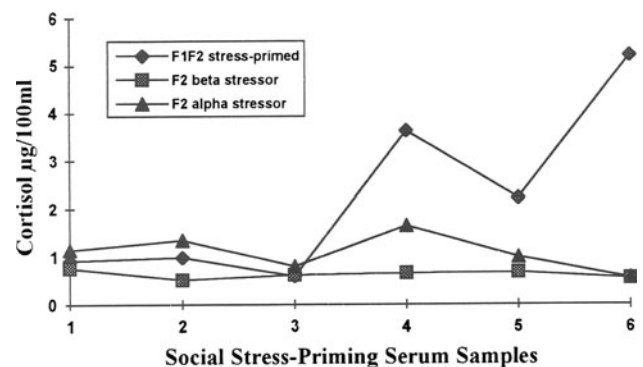

Fig. 8 Social stress-priming experiment. RIA cortisol levels in relation to social stress. 1–3 Mild to moderate stress, 4–6 high stress

With social stress-priming over time, an increase in cortisol levels over baseline was observed. The cortisol levels remain elevated during exposure to high levels of social stress but decreased to baseline once the stress was removed. Either during or soon after exposure to a prolonged period of social stress, with concomitantly elevated cortisol levels, we repeatedly observed the activation of the latent coyote defensive gape-threat in hybrids of the appropriate genetic make-up. As measured by RIA (radioimmunoassay) techniques, we determined that the changeover from the dog snarl to the coyote gape-threat in socially stress-primed late-gapers was accompanied by an approximately three-fold increase in serum cortisol over baseline levels (Fig. 9). Once the coyote genetic system is activated, however, it did not need to be maintained with high levels of cortisol. This suggests that the coyote genes were primed by social stress, acting via elevated adrenal cortical hormone levels, and further that this priming activated the appropriate genetic systems derived from their coyote ancestry, systems that were physically present, but not physiologically expressed prior to this activation. Because we did not socially stress-prime pre-pubertal hybrids, we can not be certain that attainment of sexual maturity is a prerequisite for the stress-primed onset of the gape-threat in animals of this genotype. However, based on our data, pubertal priming by sex steroids was both necessary and sufficient for some genotypes, but clearly not

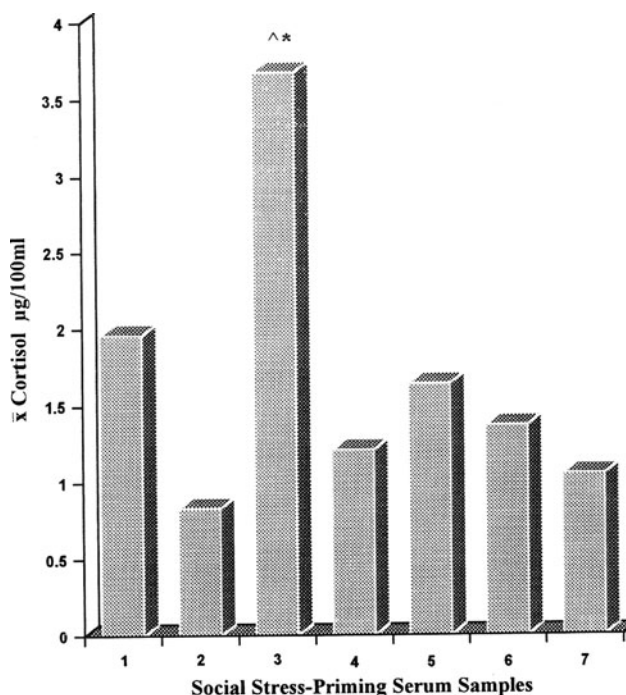

Fig. 9 RIA cortisol levels associated with onset of gape-threat during social stress-priming. F1F2 coyote–beagle hybrid #6. [^]Increased premonitory behaviors, ^{*}onset gape-threat

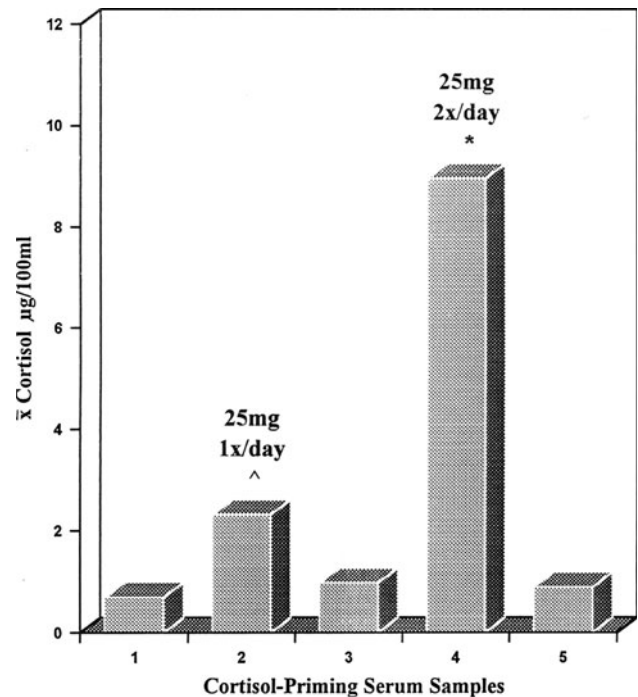

Fig. 10 RIA cortisol levels associated with onset of gape-threat during cortisol priming. F1 coyote–beagle hybrid #15. [^]Increased premonitory behaviors, ^{*}onset gape-threat

sufficient to activate the latent coyote genetic system in the hybrids that require social stress-priming in addition.

Exogenous cortisol-priming versus social-stress priming

Is social stress the necessary initiator, or are elevated cortisol levels alone, without the affect of social stress, sufficient to activate the coyote genetic system in hybrids of the appropriate genotype? To investigate this question, exogenous doses of hydrocortisone were administered daily to three hybrids that were not experiencing social stress-priming, in an effort to mimic the eliciting cortisol profile and the cortisol increase associated with the onset of the expression of the gape in stress-primed late-gapers. All three hybrids had exhibited extensive premonitory behaviors and were predicted to possibly have the genetic predisposition for the coyote behavior. This procedure was sufficient to produce the phenotypic expression of the coyote gape-threat in a male F1 where the complete coyote genome is encoded (Fig. 10), and at higher levels in his offspring produced by crossing the F1 sire with his daughter, thereby producing a close genetic relationship to him.

The F1 male was never stress-primed nor did he ever function as a dominant stressor in a social stress-priming experiment. Without experiencing the affect of social stress-priming from other canids, he expressed the

gape-threat in response to exogenous cortisol manipulation when well into maturity. Due to the father–daughter backcross male’s rearing conditions, which involved several changes of habitat and caretakers, we felt this animal was situationally stressed based on his behavior. However, this animal never experienced prolonged exposure to social stress-priming from other animals. His baseline cortisol levels were within the normal range measured for our other hybrids, so his exposure to situational stress did not elevate his cortisol levels to those observed in socially stress-primed hybrids. He expressed the full wide open mouth gape-threat while receiving exogenous doses of hydrocortisone that elevated his cortisol concentrations at minimum five times above baseline. Therefore, although neither the F1 nor his closely related offspring were socially stressed, elevated serum cortisol levels alone, without experiencing the affect of social stress, were sufficient to activate the coyote genetic system in these two hybrids. When administering exogenous doses of cortisol, the cortisol concentrations measured at the onset of the gape for these two hybrids were increased two- to five-fold over those obtained for the hybrids that responded to social stress induced cortisol increases. Since higher cortisol levels were required, we suggest that exogenously administered cortisol is not as effective as social stress induced endogenous increases for eliciting the onset of the gape-threat. One hypothesis is that there is a priming effect of moderately elevated cortisol during social stress, possibly involving an augmentation of cortisol receptors in selected brain areas.

Exogenous cortisol alone was not sufficient to produce the phenotypic expression of the coyote gape-threat in the F2 male we tested. This F2 male experienced both social stress-priming and exogenous cortisol-priming, on separate occasions. During his first exposure to social stress-priming he displayed the arched back defensive body posture characteristic of the coyote. While receiving one 25 mg dose of hydrocortisone per day for 16 days, he emitted the hiss vocalization. However, in spite of these premonitory indicators, including the pre-pubertal expression of the pre-gape, this hybrid never displayed the full wide open mouth gape-threat even though he had been rigorously exposed to all testing paradigms. Furthermore, his cortisol levels measured during cortisol-priming surpassed those induced by social stress and the elevated levels were maintained over a period of time sufficient to have produced the effect in stress-primed, as well as cortisol-primed late-gapers. This suggests that this particular F2 segregant did not possess the requisite genotype for the activation of the coyote genetic system.

To summarize, by studying the threat behavior of coyote–beagle hybrids, we have demonstrated that changes in the expression of alternatively encoded genotypes affecting behavior can occur spontaneously in some genotypes at

puberty, suggesting the influence of sex steroid hormones. In others, behavioral priming is required to switch them from one phenotype to the other. In these stress-primed late-gapers, we have hypothesized that social behavior, related to dominant status, produced elevated cortisol levels, which are involved in reprogramming the phenotypic expression of the genome, through reprogramming the behavior of those hybrids possessing an appropriately vulnerable genotype. Further research on the specific mechanisms involved would provide a better understanding of the role of genetic factors as they vary among individuals and the environmental and physiological events that interact with this genetic lability to determine the phenotype. As a hypothesis for further testing, it could be argued that social stress-priming produces more cortisol receptors in the brain, regionally, such that the cortisol surge hits those areas and de-represses the genes. With exogenous priming, the same phenomenon occurs at higher cortisol levels and therefore does not require more receptors. If the full complement of coyote genes is accessible, it appears easier to be primed.

While we are becoming more sophisticated in our ability to investigate mechanisms of behavior, the present data support the classical ethological concepts of separately inherited motor patterns that can be coordinated and expressed under the influence of particular “releasers” (Lorenz 1966; Tinbergen 1951). While the early ethologists were not geneticists, they were keen observers of behavior and recognized that specific components of behavior could be separated into distinct motor patterns that were expressed in a coordinated fashion. They called these motor components “fixed action patterns,” defining them as instinctive behaviors consisting of rigid stereotyped patterns of movement which are very similar in all individuals of a species and can usually be “released” by very simple stimuli. Ultimately they recognized that aspects of these fixed action patterns could be modified by environmental events including learning to fine tune the animal’s behavior, providing the final motor components which were most adaptive to the animal’s environment. Ethologists and behavioral psychologists debated the influence of genes versus the environment or learning in producing the final behavioral product (Lehrman 1953; Lorenz 1950). The ethologists emphasized that while all behavior has an inherited basis, it is only the potentiality that is inherited. Behavior involves the coordinated control of a number of different systems of the body. As a result, genes which affect a whole variety of morphological and physiological characters can affect behavior as well (Manning 1967). In our study of the threat gestures of coyote–beagle hybrids, behavior appears to function as a triggering mechanism by priming the neuroendocrine system especially with adrenal cortical hormones, and these determine which of an

alternative set of genes will be expressed at a particular time in development. Thus, social behavior modifies physiology, which re-regulates gene expression, which in turn, modifies behavior.

There are two other interesting inferences from our results. Based on the similarities of dog and wolf threat behaviors that set them apart from other *Canidae*, as discussed above, we suggest that these behaviors serve as taxonomic indicators of their affinity. The behavioral data are in agreement with the morphological and genetic studies (Lawrence and Bossert 1967, 1969; Shaw 1975; Wayne 1993). Finally, the work provides an additional example of the existence, function and adaptive value of communicative genes in a higher social mammal.

Discussion

Evolutionary significance of affective communicative behavior

The ability to communicate need and intent is essential for the survival of all living vertebrates. Without the capacity to signal emotional and motivational information, intra-specific aggression could threaten the survival of the species. Well-defined, stereotyped social signals prevent social disruption, permitting the formation and maintenance of socially cohesive groups. Communication also affects the evolutionary direction of social behavior because the transmission of information regarding the needs and intentions of an individual may be adaptive to the group (Buck and Ginsburg 1991).

Buck and Ginsburg (1991) emphasize the importance of communication as the “social cement” from which social behavior has evolved. They divide communication into two components: (1) biologically determined, non-voluntary, non-propositional displays; and (2) communication that is intentional and structured by learning experience. In their model, spontaneous affective communication is defined as non-intentional, non-propositional affective communication about emotions and motives, and its primary function is social coordination. In their view, experience with spontaneous affective communication throughout the course of development results in the formation of affective bonds or affinities from which species-specific behavior systems are derived. These bonds are characteristic of the social system of the species; may be hierarchically structured; and range from the species-typical bonds involved in courtship, mating, parenting, dominance hierarchies and peer coalitions, to the more complex social roles that are required for the formation and maintenance of a socially cohesive group. Defining the evolutionary significance of communication, Buck and Ginsburg (1991) propose “The

Communicative Gene Hypothesis” which states that there are “communicative genetic systems at the root of spontaneous affective communication which in turn form the basis of all social behaviors.” These systems involve a genetic coordination of sending and receiving mechanisms.

In order for communication to be subject to evolutionary processes, it must have a genetic basis. The classic studies of cricket communication (Bentley and Hoy 1974; Hoy et al. 1977) demonstrated a genetic basis for cricket calls, where portions of the same genetic system are involved in transmission and decoding capacities, constituting a fail-safe mechanism for effective signaling. Male field crickets emit species-specific and highly stereotyped calling songs which attract conspecific females. Furthermore, reciprocal F1 hybrid males produce distinctively different calls from each other and from the parental types, indicating that variability in the signals is under genetic control. Reciprocal F1 hybrid females prefer the calls of sibling hybrids to those of reciprocal hybrids. The critical factor allowing discrimination of conspecific versus heterospecific calls is hypothesized to be the temporal pattern of the call. Thus, song production by males and song recognition by females appears to have a common genetic basis. The calls and decoding capabilities are species-specific and genotype-specific and there appear to be very few degrees of freedom between the genetic encoding for emitting and decoding the calls.

Work with amphibians has shown that anurans (frogs and toads) will respond to the calls of their own species and that hybrids will selectively respond to hybrid calls (Blair 1964; Bogert 1961). Ryan (1990) observed that the call frequencies and best excitatory frequencies of cricket frog vocalizations differed between populations, but not within each population. He reports that cricket frogs emit an “advertisement” call that results in females preferring conspecific over heterospecific males. Ryan suggests that variation in the conspecific advertisement call between geographically close populations could result in local mate preferences and potentially, genetic differentiation among populations. Thus, since calls vary in a genetic manner and local genetic variants respond selectively to their “own” calls, these vocalizations may function as reproductive isolating mechanisms and from an evolutionary point of view, may facilitate speciation.

Wilkinson’s (1990) investigation of the communicative behavior of vampire bats suggests that vocalizations emitted in social situations, such as grooming sessions, may provide the mechanisms necessary for individual recognition. In vampire bats, blood sharing occurs primarily among close relatives as determined by blood enzyme markers. Furthermore, Wilkinson reports that each pup has an individually distinct call and that there is a family resemblance in vocalizations. From such evidence,

we may infer that the differences in vocalizations in bats may also have a genetic basis, and that genetics may play a role in individual recognition. In bats, where family groups are raised together, experience also plays a role in individual recognition.

From these and other studies, we may postulate that the genetics of communication delineate boundaries for sociality and speciation. In the present research, we have extended the investigation of the genetics of communication to the *Canidae*. Using the species-typical defensive threat of the coyote, which is not, to our knowledge, within the genetic repertoire of the domestic dog, we have compared it to that of the beagle as the “communicative endpoint.” We have produced and studied progeny of F1, F2, F3, F1F2 and beagle backcross generations between the two species, and conducted a developmental study of genetic and environmental factors mediating affective communicative behavior.

Defensive threat gestures and social behavior

Defensive threat behavior serves a particularly important communicative function because it helps to integrate the social behavior of a bonded group and allows aggression to be tolerated within the group. Through stereotyped offensive and defensive gestures, hierarchies and intragroup aggression can be assimilated and displayed by means of symbolic communication of intent while avoiding overt aggression. Furthermore, any hierarchical or competitive encounters involve social stress (Raleigh et al. 1991) which may activate specific hormones and, during particular stages of development, provide a mechanism for changing the relationship between genotype and phenotype.

Although the coyote has historically been considered to be a moderately social animal living in temporary pairs or small labile groups, further research has shown that coyotes have the capacity to exist in relatively stable and enduring territorial groups containing as many as seven individuals (Bekoff and Wells 1980; Moehlman 1989). It is our view that an integral part of the coyote’s capacity for long-term social relationships is its highly developed communication system. Dominance hierarchies are characteristic of such group living animals and the more labile the hierarchy, the more likely that social stress will be a common occurrence.

Wolves have a highly sophisticated social structure involving a dominance hierarchy within the pack. When a change in status occurs, usually by means of aggressive encounters, social stress accompanies the reorganization (Jenks and Ginsburg 1987). Therefore, in investigating the genetic basis of defensive threat gestures in coyote–beagle hybrids, we are not only investigating the development of the communication gestures per se, but are also studying an ecologically and evolutionarily significant situation to see

how communicative signals work to maintain the integrity of the social group, thereby enhancing its survival value and helping to maintain the genetic diversity of the species (Ginsburg 1968; Wright 1939).

The stereotyped displays of species-typical threat gestures are the basis of communicative patterns that form the “social cement” that facilitates the development of other social behaviors (Buck and Ginsburg 1991). The patterns of inheritance of the coyote defensive threat gestures in coyote–beagle hybrids provide a vivid example, in a higher vertebrate, of the complexities involved in the genetics of communication, and provide additional support for The Communicative Gene Hypothesis proposed by Buck and Ginsburg (1991).

Genetic consequences of dominance hierarchies

The social systems of many social vertebrates are characterized by dominance-deference hierarchies (De Waal 1989). Dominance hierarchies are adaptive in their own right as they promote cooperation and bonding within the group and aid in differentiating the group from the population as a whole. This can have profound genetic consequences in determining the mating structure of the species. For example, the dominance order in wolf packs may determine which individuals in a given season will breed (Jenks and Ginsburg 1987; Schotté and Ginsburg 1987). Generally it is the dominant female which will produce a litter with one of the high ranking males. Normally, as long as the dominance hierarchy remains stable, these same matings will be repeated year after year until the order changes. The genetic consequence of this is a faster evolutionary rate for the species than could be achieved with random mating. The same is true of coyotes, as they require an extended courtship prior to mating, and pairs that have bonded tend to remain together through several breeding seasons. The cooperation that is fostered by stable dominance hierarchies within which bonding has occurred is in contrast to the xenophobic reaction to members outside the group (Ginsburg et al. 1993; Goodall 1986). It has been hypothesized that these xenophobic tendencies result in a further partitioning of the gene pool, thereby promoting a more rapid evolutionary rate because of partial inbreeding on a repetitive basis (Ginsburg 1968, 1975, 1978, 1991; Ginsburg and Hiestand 1992; Wright 1939). In summary, the within-dominance hierarchies may determine the mating structure which could further restructure the gene pool (Scott 1989). Consequently, it is hypothesized that dominance hierarchies play an important role in evolution. Such hierarchies could not exist without a “social cement” to permit group recognition and bonding, and to curtail aggression. One way dominance hierarchies and other group behaviors could evolve is in conjunction with the

capacity for communication of affect and intent, so it is suggested that threat gestures are strongly rooted in an evolutionary context. This is why it appeared important to us to select natural, evolved characters with evolutionary significance. The present study of the genetic bases for the species differentiating signals, their developmental patterns, and the modification of phenotypic expression in reaction to social stress, provides an instructive model of the biological bases of these communicative behaviors.

Genetic relationships of the canids

There is remarkable genetic similarity among the four North American members of the genus *Canis*. The domestic dog (*Canis familiaris*), the coyote (*C. latrans*), the gray wolf (*C. lupus*), and the red wolf (*C. rufus*) all have the same chromosome number ($2N = 78$, and the karyological inspection of their chromosomes has revealed no different morphology (Chiarelli 1975; Wurster and Benirschke 1968; Wurster-Hill 1973). Identification of electrophoretic variants between these species has, for the most part, been successful and in fact, indicates that these species have substantially decreased incidence of polymorphic loci in comparison to numerous other mammalian groups (Seal 1975). Wayne and Jenks (1991) have reported that gray wolves and coyotes differ by 21–28 nucleotides of their cytochrome *b* sequence.

In spite of their genetic homogeneity, these four canid species are extremely different in numerous aspects of their physiology, morphology, and behavior. Such species variation includes differences in body size and proportion, color of pelage, their ages at puberty, reproductive cycles, tendency for pair bonding, courtship behavior, parental care patterns, and numerous aspects of their social behavior and organization (Bekoff 1978; Fox 1975; Ginsburg 1975, 1976b; Klinghammer 1979; Mech 1970; Moehlman 1989, 1992; Riley and McBride 1972, 1975; Scott and Fuller 1965; Stains 1975). Excluding complications arising from differences in their reproductive behavior and physiology, these four species can interbreed and their hybrid offspring are completely interfertile (Iljin 1941; Kennelly and Roberts 1969; Kolenosky 1971; McCarley and Carley 1979; Mengel 1971; Silver and Silver 1969).

Advantages of the canid model

Mice are typically the animal model of choice for most mammalian behavior genetic research because they have been genetically well characterized, are rapid breeders, and share many of their genes with humans (Nadeau and Reiner 1988). However, they are less appropriate tools for an investigation of the genetics of affective communicative behavior because their social behaviors are less varied and complex.

In contrast to mice, canids are relatively long-lived animals capable of forming more complex social organizations. In order to live in close social groups, defend territories, engage in group hunting, etc., the canids have evolved the capacity to reduce agonistic behaviors to symbolic and relatively harmless forms in highly elaborate dominance–subordination relationships, and to form group bonds in which fighting is reduced to an elaborate system of signals indicating status and intent, promoting bonding within the group, and minimizing overt aggression (Scott 1989).

The canids have additional advantages over other social vertebrates which render them uniquely appropriate for investigating the genetic basis of communication and the possibility of reprogramming the phenotypic expression of encoded genotypes. Genetic selection has resulted in a variety of breeds of dogs that differ markedly in morphology and behavior. Many of these breeds have been extensively investigated genetically, physiologically, and behaviorally (Scott and Fuller 1965; Stockard 1941). Beagles, the breed used in this study, are relatively small and easy to maintain. They are the breed of choice for many laboratory studies and their behavioral potential in a variety of rearing and learning situations has been well described (Scott and Fuller 1965). Coyotes have also been studied behaviorally (Bekoff 1978; Bekoff and Wells 1986; Fentress et al. 1987), are of a compatible size with the beagle, are morphologically and behaviorally distinct from them in many features, and can interbreed, producing fertile F1, F2, F3, and backcross offspring. Canids are highly social, and capable of complex behavior. They are responsive to conditions of rearing and to their social status in a group (Beck 1973; Frank 1987; Rabb et al. 1967). The coyote and the domestic dog differ in the type of defensive threat gestures they employ, which is the reason we have used these as our phenotype. In our pedigree studies, the elements involved in the coyote behavior show segregation and recombination in the F2, F3, F1F2 hybrids. The selective expression of one or another aspect of the two genetically encoded behavioral capacities have, in our experiments, been influenced by environmental triggers, in particular social stress. Thus, we propose that the coyote–beagle hybrids constitute an excellent model for the study of the interaction of genetic and environmental events and the mechanisms by means of which these are mediated in the selective expression of encoded genetic capacities. To our knowledge, no other mammalian species hybrids offer this array of advantages.

Consequences of domestication

The present study investigates the modification of a communicative behavioral endpoint in crosses between a

domestic and a wild canid species. The gape, hiss, and arched back defensive body posture, which we have found to be within the genetic repertoire of the coyote but not of the domestic dog, comprise an integrated and correlated behavioral pattern in the wild species. From the point of view of this study, an essential consideration is that natural species are products of phenotypic selection such that the range of genetic variability is buffered to a much narrower range of phenotypic variability (Ginsburg and Hiestand 1992). In contrast, these buffering systems have been selected against in the domestic dog, such that genetic variability is directly phenotypically expressed (Ginsburg 1976a; Scott and Fuller 1965; Stockard 1941). Consequently, in crossing the two species, we have put the coyote defensive threat pattern on the genetically unbuffered background of the domestic dog, providing an enhanced method for detecting the individual genetic components, that are now less buffered, and for determining if they segregate independently. Hybridizing buffered and unbuffered species also provides a better opportunity to detect the selective expression of genes in relation to developmental events, in the present study, those associated with steroid hormones.

By crossing breeds of domestic dogs that represented opposite extremes in morphological characteristics, Stockard (1941) showed that there can be genetic variation in all aspects of morphology and these variations can be reassembled in almost any conceivable combination. His work demonstrated that after the F1 generation, many morphological elements segregate independently and thus, heredity can be said to come in bits and pieces (Ginsburg 1976a). For example, the length of the upper and lower jaws can be genetically dissociated producing overshot and undershot animals. Body size and leg length vary independently, as do ear size and carriage, and amount of skin; in fact, many morphological variations can be recombined, constituting a “genetic erector set” (Ginsburg 1976a).

Behavioral studies with different breeds of domestic dogs (Arons 1989; Coppinger et al. 1987) further illustrate the genetic erector set concept. The Siberian husky, for example, is described as behaviorally representative of the ancestral dog, since this breed exhibits the full range of appetitive and consummatory sequences characteristic of the predatory behavior of the wild ancestral form. Border Collies, a breed of livestock conducting dogs, display the appetitive, searching and stalking behaviors but do not follow through with the full range of consummatory behaviors. Retrievers and setters go so far as to locate and retrieve the prey, but the predatory sequence is attenuated. Livestock guarding dogs exhibit virtually no aspects of the predatory sequence. Thus, it is evident that through artificial selection for specific characteristics of the ancestral behaviors, the phenotype can be limited to some

components, but not others, such that the genetic systems involved can be expressed in different combinations or separately.

Throughout the history of evolution, no similar level of variability has been observed in such a short time span (Belayev 1979). Even the theory of punctuated equilibrium, which claims that most evolutionary changes occur in rapid bursts at the time of speciation, separated by long periods of stasis, would not account for this (Smith 1983). Darwin (1859) used the process of domestication as a model for what occurs in nature over a longer period of time. How could such a rapid case of “evolution” occur? Ginsburg (Ginsburg 1976b; Ginsburg and Hiestand 1992) hypothesizes that domestic species show increased genetic variability, not as a consequence of an increased mutation rate, but rather as a result of selection against the buffering mechanisms that permit wild species to carry considerable genetic variability without disrupting the phenotype. For the domestic dog, selection against genetic buffering systems has resulted in a direct relationship between the genotype and the phenotype.

Selection in nature favors phenotypic uniformity in behavior and morphology, while preserving far more genetic variability than is phenotypically expressed. Bumpus (1899) provided early evidence for this basic tenet of Darwinian theory with his study of sparrow (*Passer domesticus*) mortality during a storm. The majority of the birds that did not survive represented a random sample of the population. However, birds that exhibited the greatest phenotypic deviations from the mean of the population were killed in higher proportions. Bumpus concluded that phenotypes representing the mean were better adapted to survive. This disparity between genotypic and phenotypic variation is accomplished by the development of a variety of buffering mechanisms including dominance, epistatic effects of non-allelic genes, limitations on penetrance, the influence of regulatory genes and other forms of gene interaction (Ginsburg 1976b; Ginsburg and Hiestand 1992).

At the population level, frequency dependent selection is one mechanism that operates to maintain genetic variability within the population. Examples of frequency dependent selection such as the “rare male effect” (Ehrman and Parsons 1977) keep genes in the population but reduce the degree to which they are expressed so that genetic variability is not lost forever, but the species does not become characterized by maladaptive extreme phenotypes. This affords the wild species the dual advantage of adaptation to current conditions while maintaining the genetic variability necessary to adapt to changing environmental conditions over evolutionary time.

Alternatively, under the process of domestication, breeders select for physical and behavioral characteristics that are useful to them or for the exotic. Insofar as such

phenotypic variants do not arise as a result of new mutations, they can most plausibly be ascribed to inbreeding and to the breakdown of the buffering systems, such that genetic variations that would otherwise be masked, come to phenotypic expression resulting in a more direct readout of the encoded genotype (Ginsburg 1976a). This allows breeders to identify the encoded genetic variation which is often manifested in discrete components which can resort in various combinations. By means of artificial selection, the breeders' preferences for unusual characteristics have resulted in the retention and expression of mutations that otherwise would have been lost, as well as the recombination of recessives that would not survive in nature. The genetic selection for behavioral and morphological characteristics of value to humans has added to the genetic variability phenotypically expressed in different breeds of domestic dogs.

Communication behavior in the dog has also been affected by the process of domestication. Here, as in other instances, the buffering systems that help to ensure that the species-typical phenotype will be maintained, have been disrupted. According to the "Communicative Gene Hypothesis" (Buck and Ginsburg 1991) communicative signals should be standardized and predictable. For wild canid species, this appears to hold true. However, the communicative patterns in the domestic dog show variability because the signal is sometimes separated from its ancestral function (Ginsburg 1976b). The domestic dog, even in feral situations, is incapable of structured pack life, partially as a consequence of the lack of a consistent communicative system (Beck 1973). Dogs emit standard signals, but the genetic aspects of the naturally evolved communicative system retained by the domestic dog are often randomly associated with context. When encountering a growling, supposedly threatening dog, quite often the dog will either run away or greet you in a friendly manner when approached. In contrast, a warning growl from a wild canid will almost certainly be followed by a bite. Thus for wild canids, the naturally selected communicative behaviors are expressed in the appropriate context, but this is not always true for the domestic dog (Ginsburg 1976b).

Another example of the breakdown of communicative behavior during the process of domestication is the occurrence of excessive and inappropriate barking in the domestic dog (Coppinger and Feinstein 1991). Whereas barking in the wild canid typically represents an alarm signal or threat, many domestic dogs have such a low threshold of stimulation for barking they seem to bark at nothing, for no apparent reason. Such inappropriate communicative behavior represents another consequence of disrupting the buffering mechanisms during domestication.

Evolutionary significance of the gape-threat

As mentioned, the species-typical defensive threat gesture of the coyote consists of a wide open mouth gape, accompanied by an aspirated hiss vocalization, an exaggerated arched back defensive posture, and an elevated, mincing gait. These behaviors are not shown by either the domestic dog or the gray wolf, and may consequently be considered as not within the genetic repertoire of these species. Both dog and wolf employ only the snarl-threat, which is often accompanied by a growl. However, the open mouth threat and sibilant vocalization characteristic of the coyote, seem to be phylogenetically widespread. Within the *Canidae*, P. Moehlman (pers. comm.) has noted the expression of these behaviors in the jackal (*C. aureus*). Other genera related to *Canis* (maned wolf, fox, hyena) may also exhibit this type of arched back wide open mouth defensive display (see Fox 1971, pp. 31–40; Stains 1975, p. 11). In fact, the wide open mouth defensive threat with the accompanying hiss vocalization is characteristic of a phylogenetically wide variety of forms from reptiles to felids. Thus, it is the lack of this type of gesture in the threat repertoire of the domestic dog and the gray wolf that is unique, and probably indicative of a close taxonomic relationship.

What is the evolutionary significance of these genetically encoded behaviors of the "coyote" threat repertoire and why are they absent in the repertoire of the domestic dog and gray wolf? Does the gape-threat serve a function that is different from the snarl-threat in the *Canidae*? For subordinate animals, the gape, hiss, and arched back defensive posture may function as appeasement gestures even though they constitute a threatening posture. This posture may indicate that the animal is not completely subordinate, though it recognizes that its opponent is dominant. Thus it may serve as a signal of deference to higher ranking animals. It is interesting that this defensive display appears to be more common among the solitary or semi-social species such as the coyote, jackal, fox, and maned wolf (Moehlman 1989). Perhaps the gape is visually a more intimidating threat display than the snarl.

What appears clear from our observation of the interactions between coyotes, beagles, their hybrids and wolves is that the gape-threat, defensive posture, and hiss vocalization are as accurately interpreted in the "non-coyote" society, where learning would not have been a factor, as they are in the "coyote" society. The genetic capacity to emit this communicative signal is, therefore, presumed to be separable from the genetic ability to decode it, which may be an older evolutionary legacy. Whether an animal expresses a snarl in a defensive context or a defensive gape does not appear to reduce or intensify the aggressive behavior of the stressor animals in our testing paradigm in

which we sought to evoke defensive threats in staged high-intensity confrontations. Furthermore, no apparent effect on the phenotypic expression of the genetically encoded threat gestures was observed whether the hybrids were raised with gapers or non-gapers. The attacks and harassments by the dominant stressor animals did not diminish or change if the stress-primed hybrid expressed the gape-threat as opposed to the defensive snarl-threat. However, when the animals are housed together, there are many other communicative signals as well as established dominance roles that provide additional contexts. Nevertheless, the wide open mouth gesture appears to be a universally understood threat that, for some reason, has been lost from the emitted genetic repertoire of domestic dogs and the North American gray wolf.

References

- Arons CD (1989) Genetic variability within a species: differences in behavior, development, and neurochemistry among three types of domestic dogs and their F1 hybrids. Unpublished Ph.D. dissertation, The University of Connecticut, Storrs
- Beck AM (1973) The ecology of stray dogs: a study of free-ranging urban animals. York Press, Baltimore
- Bekoff M (1978) Coyotes: biology, behavior, and management. Academic Press, New York
- Bekoff M, Wells MC (1980) The social ecology of coyotes. *Sci Am* 242:130–148
- Bekoff M, Wells MC (1986) Social ecology and behavior of coyotes. *Adv Stud Behav* 16:251–338
- Belayev DK (1979) Destabilizing selection as a factor in domestication. *J Hered* 70:301–308
- Bentley D, Hoy RR (1974) The neurobiology of cricket song. *Sci Am* 231:34–44
- Blair WF (1964) Isolating mechanisms and interspecies interactions in anuran amphibians. *Q Rev Biol* 39:334–344
- Bogert CM (1961) The influence of sound in the behavior of amphibians and reptiles. In: Lanyon WE, Tavolga WN (eds) Animal sounds and communication (publication no. 7). American Institute of Biological Sciences, Washington, DC
- Buck R, Ginsburg BE (1991) Spontaneous communication and altruism: the communicative gene hypothesis. In: Clark MM (ed) Prosocial behavior: review of personality and social psychology, vol 12. Sage, Newbury Park, pp 149–175
- Bumpus HC (1899) The elimination of the unfit as illustrated by the introduced sparrow, *Passer domesticus*. In: Biological lectures from the Marine 4 Biological Laboratory, Woods Hole, MA. Ginn and Co, Boston
- Chiarelli AB (1975) The chromosomes of the *Canidae*. In: Fox MW (ed) The wild canids. Van Nostrand Reinhold Co, New York, pp 40–53
- Coppinger R, Feinstein M (1991) “Hark! Hark! The dogs do bark...” and bark and bark. *Smithsonian* 21:119–129
- Coppinger R et al (1987) Degree of behavioral neoteny differentiates canid polymorphs. *Ethology* 75:89–108
- Darwin C (1859) The origin of the species (reprinted edn). Modern Library Edition, Random House, Inc, New York
- De Waal F (1989) Peacemaking among primates. Harvard University Press, Cambridge
- Ehrman L, Parsons PA (1977) The genetics of behavior. Sinauer Assoc., Inc, Sunderland
- Fentress JC et al (1987) Coyote adult-pup interactions in the first three months. *Can J Zool* 65:760–763
- Fox MW (1970) A comparative study of the development of facial expressions in canids. *Behaviour* 36:49–73
- Fox MW (1971) Behavior of wolves, dogs, and related canids. Harper and Row, New York
- Fox MW (ed) (1975) The wild canids: their systematics, behavioral ecology and evolution. Van Nostrand Reinhold Co, New York
- Frank H (ed) (1987) Man and wolf: advances, issues and problems in captive wolf research. Dr. W. Junk Publishers, The Hague
- Ginsburg BE (1968) Breeding structure and social behavior of mammals: a servo-mechanism for the avoidance of panmixia. In: Glass DC (ed) Biology and behavior genetics. The Rockefeller University Press/Russell Sage Foundation, New York, pp 117–128
- Ginsburg BE (1975) Nonverbal communication: the effect of affect on individual and group behavior. In: Pliner P, Krames L, Alloway T (eds) Nonverbal communication of aggression. Plenum Publishing Corp, New York, pp 161–173
- Ginsburg BE (1976a) Genetics of guide dog production. In: Pfaffenberger CJ, Scott JP, Fuller JL, Ginsburg BE, Bielfelt SW (eds) Guide dogs for the blind: their selection, development, and training. Vol. 1 of Developments in animal and veterinary sciences series. Elsevier Press, Amsterdam, pp 161–187
- Ginsburg BE (1976b) Evolution of communication patterns in animals. In: Hahn ME, Simmel EC (eds) Communicative behavior and evolution. Academic Press, New York, pp 59–79
- Ginsburg BE (1978) The genetics of social behavior. In: Bateson PPG, Klopfer PH (eds) Perspectives in ethology, vol 3. Plenum Publishing Corp, New York, pp 1–15
- Ginsburg BE (1991) Origins and dynamics of social organization in primates and in wolves: cooperation, aggression and hierarchy. In: Somit A, Wildenmann R (eds) Hierarchy and democracy. Southern Illinois University Press, Carbondale, pp 45–62
- Ginsburg BE, Hiestand L (1992) Humanity’s “best friend”: the origins of our inevitable bond with dogs. In: Davis H, Balfour D (eds) The inevitable bond: examining scientist–animal interactions. Cambridge University Press, Cambridge, pp 93–108
- Ginsburg BE et al (1993) The roots and consequences of xenophobia. In: History of European ideas. Pergamon Press Ltd, Oxford, pp 35–40
- Goodall J (1986) The chimpanzees of Gombe patterns of behavior. Belknap Press of Harvard University Press, Cambridge
- Hoy RR et al (1977) Hybrid cricket auditory behavior: evidence for genetic coupling in animal communication. *Science* 195:82–83
- Iljin NA (1941) Wolf–dog genetics. *J Genet* 42:359–414
- Jenks SM, Ginsburg BE (1987) Socio-sexual dynamics in a captive wolf pack. In: Frank H (ed) Man and wolf. Dr. W. Junk Publishers, The Hague, pp 375–399
- Kennelly JJ, Roberts JD (1969) Fertility of coyote–dog hybrids. *J Mammol* 50:830–831
- Klinghammer E (ed) (1979) The behavior and ecology of wolves. Garland Press, New York
- Kolenosky GB (1971) Hybridization between wolf and coyote. *J Mammol* 52:446–449
- Lawrence B, Bossert WH (1967) Multiple character analysis of *Canis lupus*, *latrans*, and *familiaris* with a discussion of the relationships of *Canis niger*. *Am Zool* 7:223–232
- Lawrence B, Bossert WH (1969) The cranial evidence for hybridization in New England *Canis*. *Brevoria* 330:1–13
- Lehner PN (1978) Coyote communication. In: Bekoff M (ed) Coyotes: biology, behavior, and management. Academic Press, New York, pp 128–159
- Lehrman DS (1953) A critique of Konrad Lorenz’s theory of instinctive behavior. *Q Rev Biol* 28:337–363

- Lilly MP et al (1986) Pituitary–adrenal responses to repeated small hemorrhage in conscious dogs. *Am J Physiol* 251:R1200–R1207
- Lorenz K (1950) The comparative method in studying innate behaviour patterns. *Symp Soc Exp Biol* 4:221–268
- Lorenz KZ (1966) *Evolution and modification of behavior*. Methuen, London
- Manning A (1967) *An introduction to animal behavior*. Addison-Wesley Publishing Co, Reading
- McCarley H, Carley CJ (1979) Recent changes in distribution and status of wild red wolves (*Canis rufus*). In: *Endangered species report 4*. U.S. Fish and Wildlife Service, Albuquerque, pp 1–38
- Mech DL (1970) *The wolf: the ecology and behavior of an endangered species*. Natural History Press, Garden City
- Mengel RM (1971) A study of dog–coyote hybrids and implications concerning hybridization in *Canis*. *J Mammol* 52:316–336
- Moehlman PD (1989) Intraspecific variation in canid social systems. In: Gittleman JL (ed) *Carnivore behavior, ecology, and evolution*. Cornell University Press, Ithaca, pp 143–163
- Moehlman PD (1992) Introduction. In: Sheldon JW (ed) *Wild dogs: the natural history of the non-domestic Canidae*. Academic Press, San Diego, pp 1–39
- Nadeau JH, Reiner AH (1988) Linkage and synteny homologies in mouse and man. In: *Current topics in microbiology and immunology*, vol 137. Springer, Berlin, pp 39–40
- Rabb GB et al (1967) Social relationships in a group of captive wolves. *Am Zool* 7:305–311
- Raleigh MJ et al (1991) Serotonergic mechanisms promote dominance acquisition in adult male vervet monkeys. *Brain Res* 559:181–190
- Riley GA, McBride RT (1972) A survey of the red wolf (*Canis rufus*). Special scientific report on wildlife no. 162. U.S. Fish and Wildlife Service, Washington, DC
- Riley GA, McBride RT (1975) A survey of the red wolf (*Canis rufus*). In: Fox MW (ed) *The wild canids: their systematics, behavioral ecology, and evolution*. Van Nostrand Reinhold Co, New York, pp 263–277
- Ryan MJ (1990) Signals, species, and sexual selection. *Am Sci* 7:46–52
- Sapolsky RM, Ray JC (1989) Styles of dominance and their correlates among wild olive baboons (*Papio anubis*). *Am J Primatol* 18:1–13
- Schotté CS, Ginsburg BE (1978) Communication behavior of coyotes, beagles, and their hybrids. Paper presented at BGA, Davis, CA
- Schotté CS, Ginsburg BE (1987) Development of social organization and mating in a captive wolf pack. In: Frank H (ed) *Man and wolf*. Dr. W. Junk Publishers, The Hague, pp 349–374
- Scott JP (1989) *The evolution of social systems. Monographs in psychobiology: an integrated approach*, vol 3. Gordon and Breach Science Publishers, New York
- Scott JP, Fuller JL (1965) *Dog behavior: the genetic basis*. University of Chicago Press, Chicago, IL
- Seal US (1975) Molecular approaches to taxonomic problems in the *Canidae*. In: Fox MW (ed) *The wild canids*. Van Nostrand Reinhold Co, New York, pp 27–39
- Selye H (1950) *Stress*. Acta, Montreal
- Shaw JH (1975) *Ecology, behavior and systems of the red wolf (Canis rufus)*. Unpublished Ph.D. dissertation, Yale University, New Haven
- Silver H, Silver WT (1969) Growth and behavior of the coyote-like canid of northern New England with observations on canid hybrids. *Wildlife monographs*, No. 7, Oct. 1969
- Smith JM (1983) The genetics of stasis and punctuation. *Annu Rev Genet* 17:11–25
- Stains HJ (1975) Distribution and taxonomy of the *Canidae*. In: Fox MW (ed) *The wild canids: their systematics, behavioral ecology and evolution*. Van Nostrand Reinhold Co, New York, pp 3–26
- Stockard CR (1941) *The genetic and endocrine basis for differences in form and behavior*. The Wistar Institute of Anatomy and Biology, Philadelphia
- Tinbergen N (1951) *The study of instinct*. Oxford University Press, London
- Wayne RK (1993) Molecular evolution of the dog family. *Trends Genet* 9:218–224
- Wayne RK, Jenks SM (1991) Mitochondrial DNA analysis implying extensive hybridization of the endangered red wolf *Canis rufus*. *Nature* 351:565–568
- Wilkinson GS (1990) Food sharing in vampire bats. *Sci Am* 262(2):76–83
- Wright S (1921) Systems of mating. *Genetics* 6:172. In: Lush JL (ed) *Animal breeding plans (1945)*. Iowa State University Press, Ames, pp 264–293
- Wright S (1939) *Statistical genetics in relation to evolution*. Hermann, Paris
- Wurster DH, Benirschke K (1968) Comparative cytogenetic studies in the order Carnivora. *Chromosoma* 24:336–382
- Wurster-Hill DH (1973) Chromosomes of eight species from five families of Carnivora. *J Mammol* 54(3):753–760